

Globally Approved for Accuracy and Safety



Process Weighing

Due to the hermetically sealed design, MTB is ideal for harsh environments in process or food applications. The full set of approvals makes it the right choice for your application.



Tank Weighing

The capacity range from 5kg to 500kg makes the weighing of small vessels possible. The stainless steel design, hermetic sealing and IP68 protection provides the best reliability in these applications.



ULTRAMOUNT Module

With the optional stainless steel ULTRAMOUNT weigh module METTLER TOLEDO provides a complete solution for vessel weighing in harsh environments.



MTB Load Cell

The MTB load cell features:

- OIML C3, NTEP IIIM 5,000d and IIIS 3,000d approvals
- ATEX Zone1/2 and 21/22 approvals
- FM Class I,II,III Div 1&2 approvals for USA & Canada
- Stainless steel
- Hermetically sealed design
- IP68 protection class
- All approvals standard on every Load Cell

The MTB is approved for use in various applications in Europe, Asia, America and almost everywhere else in the world. If an approval is required, the MTB probably already complies.

If ever needed for hazardous areas later, the MTB is already prepared.

MTB Load Cell Specifications

Parameter		unit of measure	Specification							
Model No:			MTB							
Rated Capacity (R.C.)		kg (lb, nominal)	5 (11)	10 (22)	20 (44)	50 (110)	100 (220)	200 (441)	300 (661)	500 (1102)
Rated Output		mV/V @R.C.	2 ± 0.1%							
Zero load Output		%R.C.	≤ 1							
Combined Error ^{1), 2)}		%R.C.	≤ 0.018							
Repeatability Error		%A.L. ³⁾	≤ 0.01							
Creep, 30 minute		%A.L.	≤ 0.0167							
Min. Dead Load Output Return (DR), 30 min		%A.L.	≤ 0.0167							
Temperature Effect on	Min Dead load Output	%R.C./°C (./°F)	≤ 0.001 (0.0006)							
	Sensitivity ²⁾	%A.L./°C (./°F)	≤ 0.0009 (0.0005)							
Temperature Range	Compensated	°C (°F)	-10 ~ +40 (+14 ~ +104)							
	Operating	°C (°F)	-20 ~ +65 (-4 ~ +150)							
	Safe Storage	°C (°F)	-40 ~ +80 (-40 ~ +176)							
OIML / European Approval ⁴⁾	OIML Cert. No.		R60/2000-NL 1-05.18							
	European Cert. No.		NMI TC6035							
	Class		C3							
	n _{max}		3000							
	Y		12000							
	PLC		0.7							
	Humidity Symbol		none							
NTEP Approval ⁴⁾	Min. dead load	kg (lb)	0 (0)							
	Number		06-045							
	Class		IIIS / III M							
	n _{max}		3000 / 5000							
	V _{min}	kg (lb)	R.C. / 12000							
ATEX Approval ⁴⁾	Min. dead load	kg (lb)	0 (0)							
	Number, Cat 2		KEMA 05ATEX1178 X (-40°C ~ +50°C)							
	Number, Cat 3		KEMA 05ATEX1179 (-40°C ~ +50°C)							
	Rating			II 2 G Ex ib IIC T4						
				II 2 D Ex ibD 21 IP6X T135°C						
				II 3 G Ex nA II T4						
				II 3 G Ex nL IIC T4						
Entity Parameters		II 3 D Ex tD A22 IP6X T135°C								
Number, USA		Ui=25V, li=600mA, Pi=1.25W, Ci=5nF, Li=30µH								
Number, Canada		3005885								
Factory Mutual Approval ⁴⁾	Rating		3025753C							
	Entity Parameters		IS / I,II,III / 1 / ABCDEFG / T4							
	System Drawing No, USA		NI / I / 2 / ABCD / T6							
	System Drawing No, CDN		S / II,III / 2 / FG / T6							
	Entity Parameters		Vmax=25V, lmax=600mA, Pi=1.25W, Ci=0, Li=0							
Excitation Voltage	Recommended	V AC/DC	5-15							
	Maximum	V AC/DC	20							
Terminal Resistance	Excitation	Ω	≥ 383							
	Output	Ω	350 ± 1							
Insulation Resistance @50VDC		MΩ	> 5000							
Breakdown Voltage		V AC	> 500							
Material	Spring Element		stainless steel							
	Enclosure		316 stainless steel							
	Cable entry fitting		304 stainless steel							
	Cable		PVC							
Protection	Type		welded							
	IP Rating		IP 68							
	NEMA Rating		NEMA 6/6P							
Load Limit	Safe	%R.C.	150							
	Ultimate	%R.C.	300							
Safe Dynamic Load		%R.C.	70							
Fatigue Life		cycles @R.C.	>1,000,000							
Direction of Loading			beam							
Deflection @ R.C., nominal	mm (in)		0.30 (0.012)	0.40 (0.016)			0.5 (0.020)	0.75 (0.030)	1.12 (0.044)	
Weight, nominal	kg (lb)		0.6 (1.3)							
Cable Length	m (ft)		3 (10); 5 (16.6)							
Barometric Pressure Effect on Zero Load Output	kg/kPa (lb/in.Hg)		none							
Safe Side Load		%R.C.	100							
Mounting Screw	Grade		8.8 (grade 5)							
	Size/thread	mm (in)	M8x1.25 (5/16-18 UNC)						M10x1.5 (3/8-16 UNC)	
	Engaged Length	mm (in)	-							
	Torque, nominal	N.m (ft-lb)	15 (11)							20 (14.5)

¹⁾ Error due to the combined effect of non-linearity and hysteresis

²⁾ Typical values only. The sum of errors due to Combined Error and Temperature Effect on Sensitivity comply with the requirements of OIML R60 and NIST HB44.

³⁾ A.L. = Applied Load

⁴⁾ See certificate for complete information.

⁵⁾ 60 minutes

MTB Load Cell Dimensional Drawings mm [inch]

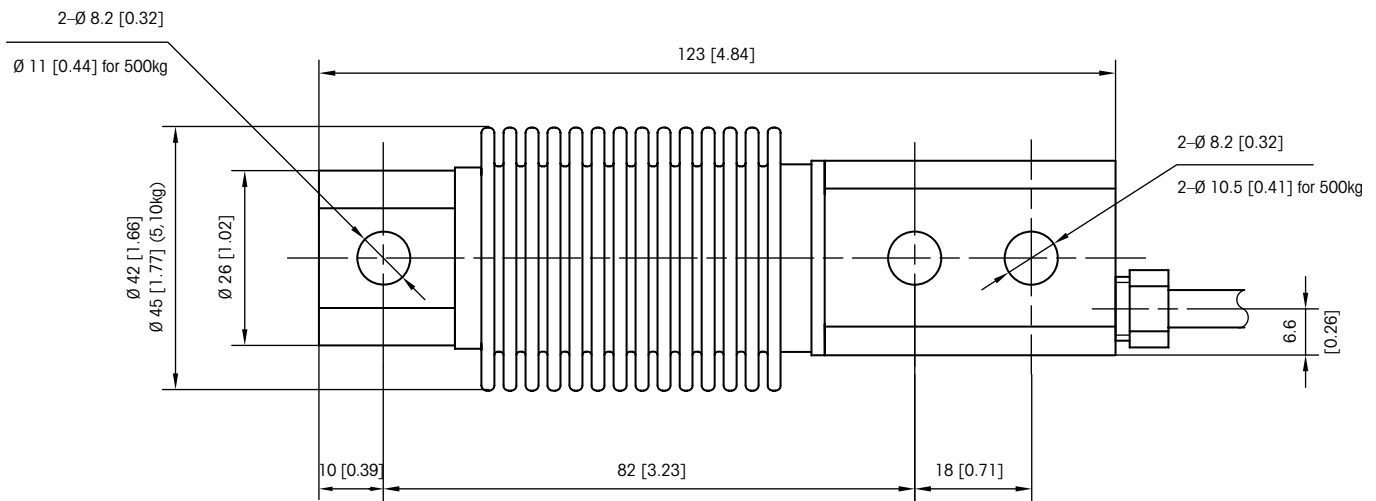
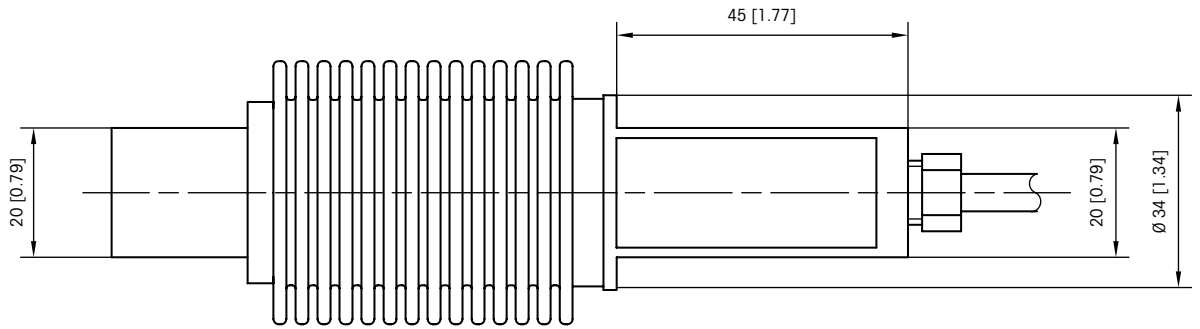

MTB 5, 10, 20, 50, 100, 200, 300, 500

MTB Ball/Cup Load Introduction mm [inch]

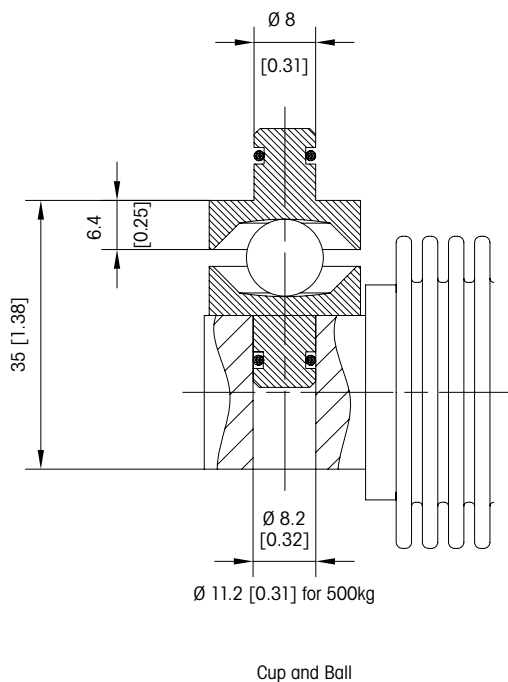

MTB Spacer mm [inch]

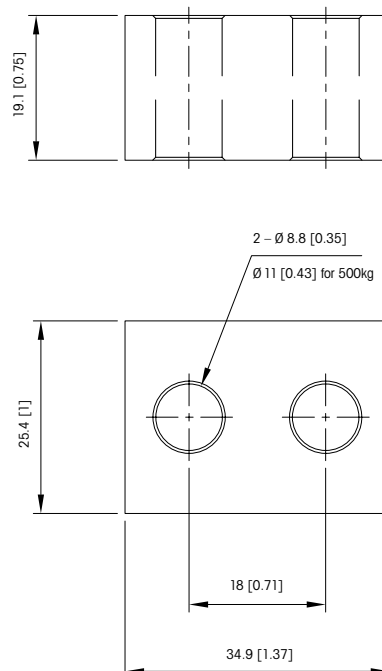

MTB Expansion + Vibration Kit EVK mm [inch]

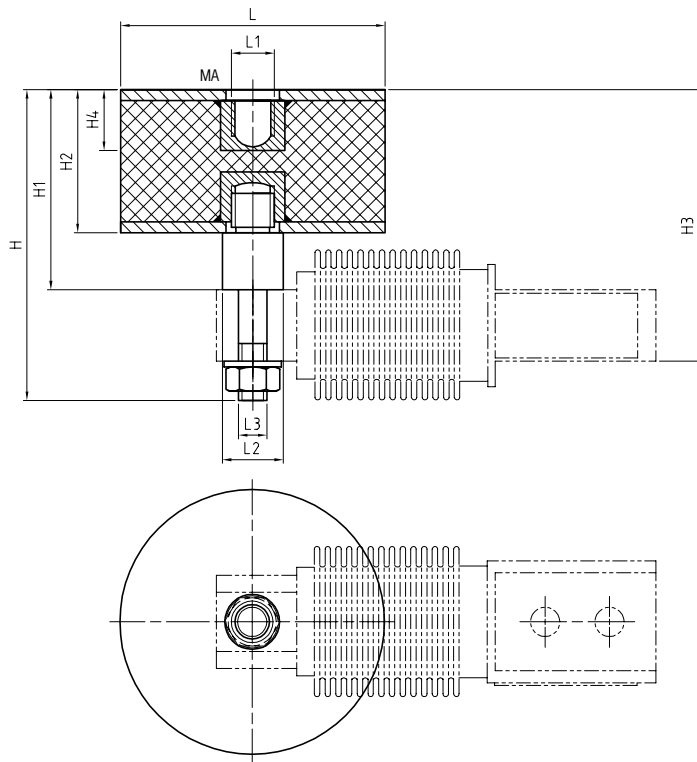

Materials: Stainless steel, NBR 70

Capacity	Dimensions and Locations												
	L	L1	L2	L3	H	H1	H2	H3	H4	Smax ¹	Fs max ²	Ft ³	MA
5-300 kg	ø74 [ø2.91]	M12	17 [0.67]	M8	87 [3.43]	56 [2.20]	40 [1.57]	76 [2.99]	14 [0.55]	±3 [±0.12]	450 N	500 N	20 Nm [14.5 lb-ft]
500 kg	ø74 [ø2.91]	M12	17 [0.67]	M8	87 [3.43]	56 [2.20]	40 [1.57]	76 [2.99]	14 [0.55]	±3 [±0.12]	450 N	500 N	20 Nm [14.5 lb-ft]

1) Max lateral displacement 2) Max lateral force of Smax 3) Max Tension Force

MTB Foot Kit FTK mm [inch]

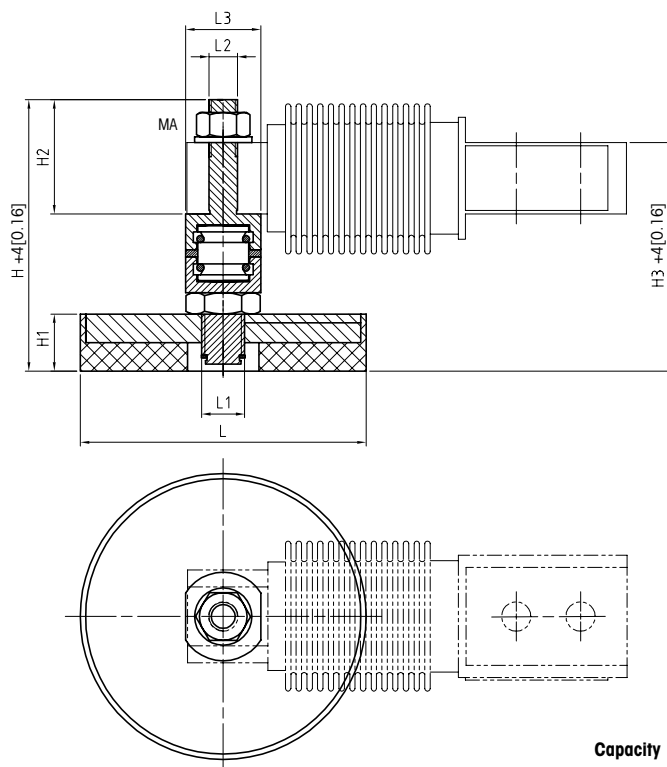

Materials: Stainless steel, NBR 70

Capacity	Dimensions and Locations									
	L	L1	L2	L3	H	H1	H2	H3	H4	MA
5-300 kg	ø80 [ø3.15]	M12	M8	21 [0.83]	76 [2.99]	16 [0.63]	32 [1.26]	64 [2.52]	20 Nm [14.5 lb-ft]	20 Nm [14.5 lb-ft]
500 kg	ø80 [ø3.15]	M12	M10	21 [0.83]	76 [2.99]	16 [0.63]	32 [1.26]	64 [2.52]	20 Nm [14.5 lb-ft]	20 Nm [14.5 lb-ft]

MTB Base Plate Kit BPK mm [inch]

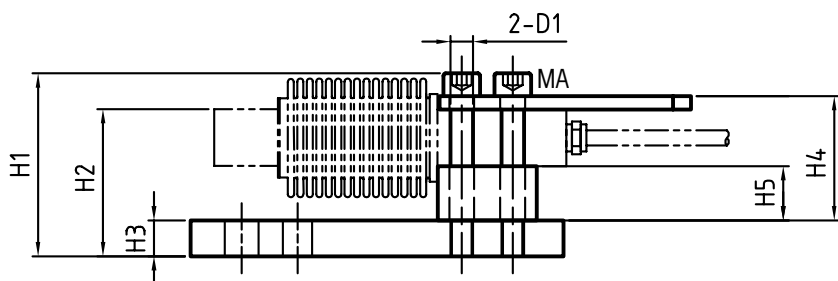
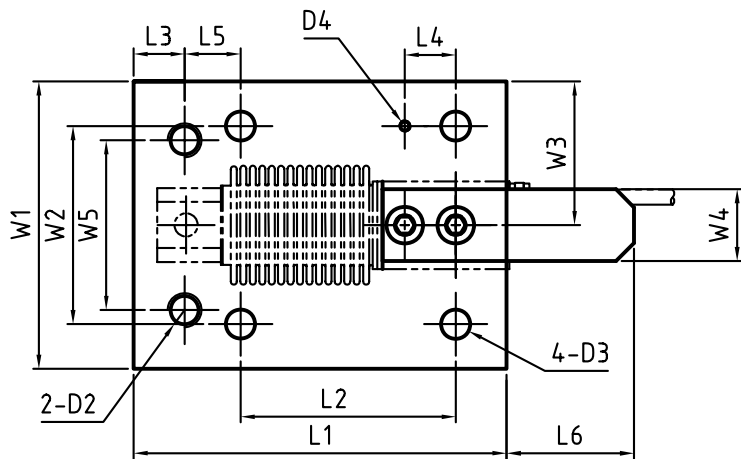

Materials: Stainless steel

Capacity	Dimensions and Locations									
	L1	L2	L3	L4	L5	L6	W1	W2	W3	W4
5-300 kg	131.8 [5.19]	76 [2.99]	18 [0.70]	18 [0.70]	24 [0.94]	45 [1.77]	101.6 [4]	70 [2.75]	50.8 [2]	25.4 [1]
500 kg	131.8 [5.19]	76 [2.99]	18 [0.70]	18 [0.70]	24 [0.94]	45 [1.77]	101.6 [4]	70 [2.75]	50.8 [2]	25.4 [1]

Capacity	Dimensions and Locations										
	W5	H1	H2	H3	H4	H5	D1	D2	D3	D4	MA
5-300 kg	60 [2.36]	64.6 [2.54]	51.9 [2.04]	12.7 [0.50]	43.9 [1.72]	19.1 [0.75]	M8	M12	∅10.3 [∅0.40]	M4	15 Nm [11 ft-lb]
500 kg	60 [2.36]	66.6 [2.62]	51.9 [2.04]	12.7 [0.50]	43.9 [1.72]	19.1 [0.75]	M10	M12	∅10.3 [∅0.40]	M4	20 Nm [14.5 ft-lb]

MTB Load Cell Order Information

Description	Item No.
LOAD CELL MTB 5 KG, 3 M	71209934
LOAD CELL MTB 10 KG, 3 M	71209642
LOAD CELL MTB 20 KG, 3 M	71201556
LOAD CELL MTB 50 KG, 3 M	71201557
LOAD CELL MTB 100 KG, 3 M	71201558
LOAD CELL MTB 200 KG, 3 M	71201559
LOAD CELL MTB 300 KG, 3 M	71201560
LOAD CELL MTB 500 KG, 3 M	71209472
LOAD CELL MTB 5 KG, 5 M	72208033
LOAD CELL MTB 10 KG, 5 M	72208034
LOAD CELL MTB 20 KG, 5 M	72208035
LOAD CELL MTB 50 KG, 5 M	72208036
LOAD CELL MTB 100 KG, 5 M	72208037
LOAD CELL MTB 200 KG, 5 M	72208038
LOAD CELL MTB 300 KG, 5 M	72208039
LOAD CELL MTB 500 KG, 5 M	72208040
BALL/CUP MTB 5-300 KG	72191495
SPACER MTB 5-300 KG	72191496
BALL/CUP MTB 500 KG	72191497
SPACER MTB 500 KG	72191498
BASE PLATE KIT BPK SS MTB 5-300 KG	72208676
BASE PLATE KIT BPK SS MTB 500 KG	72208677
EXPANSION + VIBR. KIT EVK MTB 5-300 KG	72208678
EXPANSION + VIBR. KIT EVK MTB 500 KG	72208679
FOOT KIT FTK SS MTB 5-300 KG	72208680
FOOT KIT FTK SS MTB 500 KG	72208681

Bolded entries are stocked

MTB Load Cell Cable Colours

Colour	Function
Green	+ Excitation
Black	- Excitation
White	+ Signal
Red	- Signal
Yellow	+ Sense
Blue	- Sense
Yellow (Long)	Shield

Global Approvals

The MTB is provided with all listed approvals. No need to think about options and additional charges. Simplifies the conduct of global business, order processing and service-part stocking.



ServiceXXL[®] Tailored Services

Worldwide Services

Use METTLER TOLEDO service including fast parts availability from our local supply or one of our logistics centers in Europe, Asia and America. Trained technicians can assist in professional service, installation and approval worldwide.

Weighing Electronics

METTLER TOLEDO offers a complete family of electronics from simple weighing to application solutions for filling, stock control, batching, formulation, counting, checkweighing.



Quality certificate ISO 9001
Environment certificate ISO 14001

Subject to technical changes.
© 08/2011 Mettler-Toledo AG
Printed in Switzerland MTSI 44099786
MarCom Industrial

www.mt.com

Visit for more information