

Fully Approved for Accuracy and Safety

**Floor Scales**

Use the 0745A load cell in platform and floor scales. Due to the hermetic welded design the 0745A is ideal for harsh environments in process and food applications. The full set of approvals provides maximum applicability and safety in these applications.

**Tank Weighing**

The capacity range from 110kg to 4.4t allows the weighing of tanks and silos. The stainless steel design, hermetic sealing and IP68 protection provides the best reliability in tank and hopper weighing applications in harsh environments in process and food applications.

**CENTERLIGN Weigh Module**

The optional METTLER TOLEDO CENTERLIGN weigh module allows one to convert an existing system into a precise weighing system. It is ideal for dynamic loading applications such as belt scales and conveyor scales. Available in epoxy painted steel or stainless steel.

**FLEXMOUNT Weigh Module**

The optional METTLER TOLEDO FLEXMOUNT weigh module allows one to convert an existing system into a precise weighing system. It is ideal for static loading applications such as hopper weighing and tank weighing. Available in epoxy painted steel or stainless steel.

**0745A Beam Load Cell**

Every 0745A beam load cell features:

- OIML C3 and NTEP III M 5.000d approvals (except 110kg)
- ATEX Zone1/2 and 21/22 approvals
- FM Class I,II,III Div 1&2 approvals
- Stainless steel
- Hermetically sealed design
- IP68 protection class

The 0745A is approved for use in various applications in Europe, Asia, America and almost everywhere else in the world. If an approval is required, the 0745A probably already complies.

Even if needed for hazardous areas later, the 0745A is already prepared.

0745A Load Cell Specifications

Parameter		unit of measure	Specification						
Model No.			0745A						
Rated Capacity (R.C.)		kg (lb)	110 (250)	220 (500)	550 (1250)	1100 (2500)	2200 (5000)	4400 (10000)	
Rated Output		mV/V @R.C. – kg mV/V @R.C. – lb	0.970 ± 0.002 1.000 ± 0.002	1.940 ± 0.002 2.000 ± 0.002					
Zero load Output		%R.C.	≤ 1						
Combined Error ^{1) 2)}		%R.C.	0.03						
Repeatability Error		%A.L. ³⁾	≤ 0.01						
Creep, 30 minute		%A.L.	≤ 0.0167						
Min. Dead Load Output Return (DR), 30 min		%A.L.	≤ 0.0167						
Temperature Effect on		Min. Dead load Output	%R.C./°C (./°F)	0.0027 (0.0015)					
		Sensitivity ²⁾	%A.L./°C (./°F)	≤ 0.0020 (0.0010)					
		Compensated	°C (°F)	-10 to +40 (+14 to +104)					
Temperature Range		Operating	°C (°F)	-20 to +65 (-4 to +150)					
		Safe Storage	°C (°F)	-40 to +80 (-40 to +176)					
OIML / European Approval ⁴⁾		OIML Cert. No.	-	R60/1991-US-99.01					
		European Cert. No.	-	NMI TC2154					
		Class	-	C3					
		n _{max}	-	3000					
		V _{min}	kg (lb)	0.032 (0.070)	0.079 (0.175)	0.159 (0.35)	0.317 (0.70)	0.635 (1.40)	
		PLC	-	0.7					
		Humidity Symbol	-	none					
		Min. dead load	kg (lb)	-	0 (0)				
NTEP Approval ⁴⁾		Number	-	92-108					
		Class	-	III M					
		n _{max}	-	5000					
		V _{min}	kg (lb)	0.032 (0.070)	0.079 (0.175)	0.159 (0.35)	0.317 (0.70)	0.635 (1.40)	
		Min. dead load	kg (lb)	-	0 (0)				
ATEX Approval ⁴⁾		Number, cat. 2	-	KEMA 03ATEX1069					
		Number, cat. 3	-	KEMA 03ATEX1070					
		Rating	-	II 2 D Ex tD A21 IP6X T100°C II 3 G Ex nA II T4 II 3 G Ex nL IIC T4 II 3 D Ex tD A22 IP6X T100°C					
		Entity Parameters	-	Ui/Un=25V, Ii=600mA, Pi=1.25W, Ci=5nF, Li=30µH					
Factory Mutual Approval ⁴⁾		Number	-	3005885					
		Rating	-	IS / I, II, III / 1 / ABCDEFG / T4 NI / I / 2 / ABCD / T6 S / I, II, III / 2 / FG / T6					
		Entity Parameters	-	Vmax=25V, Imax=600mA, Pi=1.25W, Ci=0, Li=29µH					
		System Drawing No	-	158574R					
Excitation Voltage		Recommended	V AC/DC	5-15					
		Max.	V AC/DC	20					
Terminal Resistance		Excitation	Ω	≥ 385					
		Output	Ω	350 ± 2					
Insulation Resistance @50VDC			MΩ	> 5000					
Breakdown Voltage			V AC	> 500					
Material		Spring Element		Stainless steel					
		Enclosure		304 Stainless steel					
		Cable entry fitting		304 Stainless steel					
		Cable		Polyurethane & FEP					
Protection		Type		welded					
		IP Rating		IP 68					
		NEMA Rating		NEMA 6/6P					
Load Limit		Safe	%R.C.	150					
		Ultimate	%R.C.	300					
Safe Side Load ⁵⁾			%R.C.	100					
Safe Dynamic Load			%R.C.	70					
Fatigue Life			cycles @R.C.	>1,000,000					
Direction of Loading				beam					
Deflection @ R.C., nominal		mm (in)	0.07 (0.003)	0.14 (0.005)	0.23 (0.009)	0.34 (0.013)	0.52 (0.020)	0.62 (0.024)	
Overload Protection				yes			no		
Weight, nominal		kg (lb)	0.9 (2)				1.3 (2.9)	2 (4.4)	
Cable Length		m (ft)	2.2, 4.5, 9.1, 18.2 (7.5, 15, 30, 60)						
Barometric Pressure Effect on Zero Load Output		kg/kPa (lb/in.Hg)	none						
Mounting Screw		Grade	10.9 (Grade 8)						
		Size/thread	mm (in)	M12 (1/2-13 UNC)				M18x1.5 (3/4-10 UNC)	
		Engaged Length	mm (in)	-					
		Torque, nominal	N.m (ft-lb)	136 (100)				340 (250)	

¹⁾ Error due to the combined effect of non-linearity and hysteresis

²⁾ Typical values only. The sum of errors due to Combined Error and Temperature Effect on Sensitivity comply with the requirements of OIML R60 and NIST HB44.

³⁾ A.L. = Applied Load

⁴⁾ See certificate for complete information.

⁵⁾ Protect mounting screws from shear.



0745A Load Cell Dimensional Drawings mm [inch]

Model	Capacity	Dimensions and locations																	
		D (2x)	D1	D2	H	H1	H2	H3	H4	H5	H6 (1)	L	L1	L2	L3	L4	L5 (1)	W	W1
0745/0745A	110–1100 kg	13.0	22.2	15.9	30.2	1.8	17.3	16	4.5	7.9	0.38	133.3	57.7	101.6	25.4	15.4	6.4	30.7	5.2
	[500–2500 lb]	[0.51]	[0.88]	[0.62]	[1.19]	[0.07]	[0.68]	[0.63]	[0.18]	[0.31]	[0.015]	[5.25]	[2.27]	[4.0]	[1.0]	[0.61]	[0.25]	[1.21]	[0.21]
0745/0745A	2200 kg	13.0	22.2	15.9	36.6	2.5	22.9	19.6	9.2	12.7	2.5	136.6	57.9	101.6	25.4	18.4		36.8	5.8
	[5000 lb]	[0.51]	[0.88]	[0.62]	[1.44]	[0.10]	[0.90]	[0.77]	[0.36]	[0.50]	[0.10]	[5.38]	[2.28]	[4.0]	[1.0]	[0.72]		[1.45]	[0.23]
0745/0745A	4400 kg	19.3	34.9	22.2	42.9	2.4	29.3	22.6	10.8	17.8	2.4	171.5	73.8	133.3	38.1	21.4		42.9	6.4
	[10 000 lb]	[0.76]	[1.38]	[0.88]	[1.69]	[0.09]	[1.16]	[0.89]	[0.43]	[0.70]	[0.09]	[6.75]	[2.91]	[5.25]	[1.50]	[0.84]		[1.69]	[0.25]

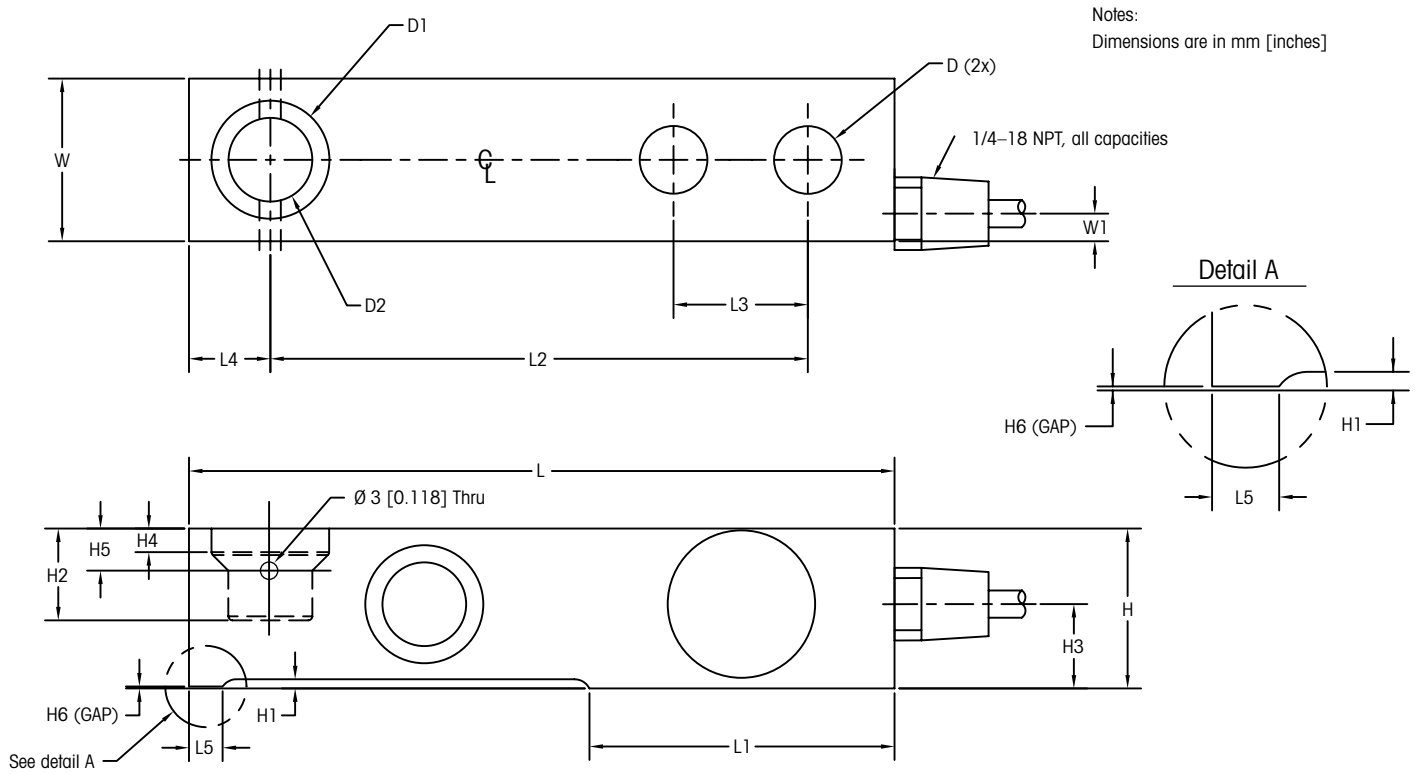

Notes (1):
Overload stop on 250–2500lb only [220–1100kg only]

0745A Foot Kit FTK mm [inch]

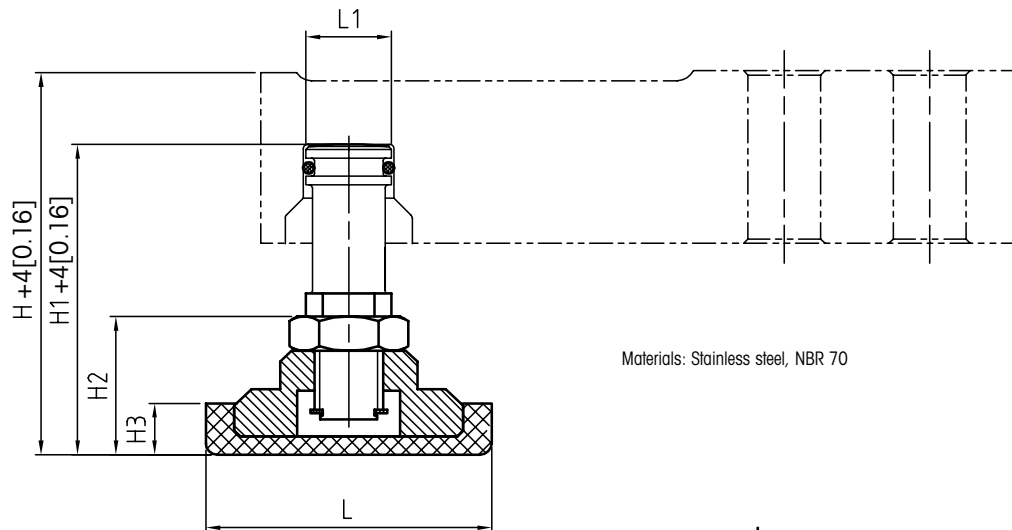

Materials: Stainless steel, NBR 70

Capacity	Dimensions and Locations					
	L	L1	H	H1	H2	H3
110 kg-1.1 t	ø50 [ø1.97]	ø15 [ø0.59]	66.8 [2.14]	54.3 [2.14]	24.2 [0.95]	9 [0.35]
2.2 t	ø50 [ø1.97]	ø15 [ø0.59]	66.5 [2.14]	54.3 [2.14]	24.2 [0.95]	9 [0.35]
4.4 t	ø70 [ø2.76]	ø15 [ø0.59]	91.2 [3.59]	80 [3.15]	38.5 [1.52]	17 [0.67]

0745A Expansion Kit EK mm [inch]

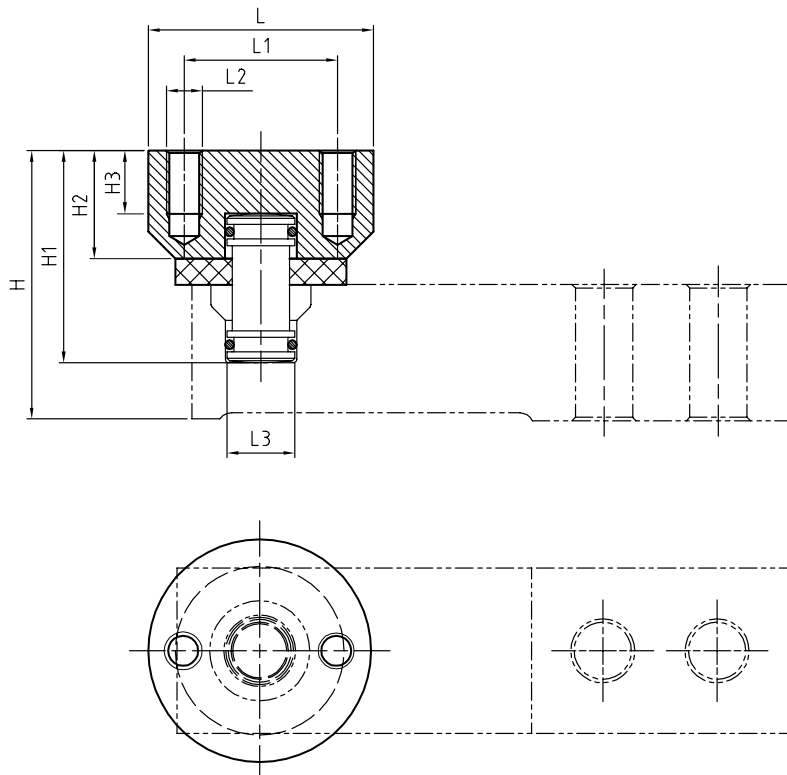

Materials: Stainless steel, Polyethylene foam

Capacity	Dimensions and Locations									
	L	L1	L2	L3	H	H1	H2	H3	Smax*	
110 kg-1.1 t	ø50 [ø1.97]	34 [1.34]	M8	ø15 [ø0.59]	59.6 [2.35]	47.1 [1.85]	24 [0.94]	14 [0.55]	±3 mm [±0.12]	
2.2 t	ø50 [ø1.97]	34 [1.34]	M8	ø15 [ø0.59]	63.5 [2.50]	52.3 [2.06]	24 [0.94]	14 [0.55]	±3 mm [±0.12]	
4.4 t	ø60 [ø2.36]	45 [1.77]	M10	ø21.5 [ø0.85]	73.6 [2.90]	62.4 [2.46]	28 [1.10]	17 [0.67]	±3 mm [±0.12]	

* Max lateral displacement

0745A Expansion + Vibration Kit EVK mm [inch]

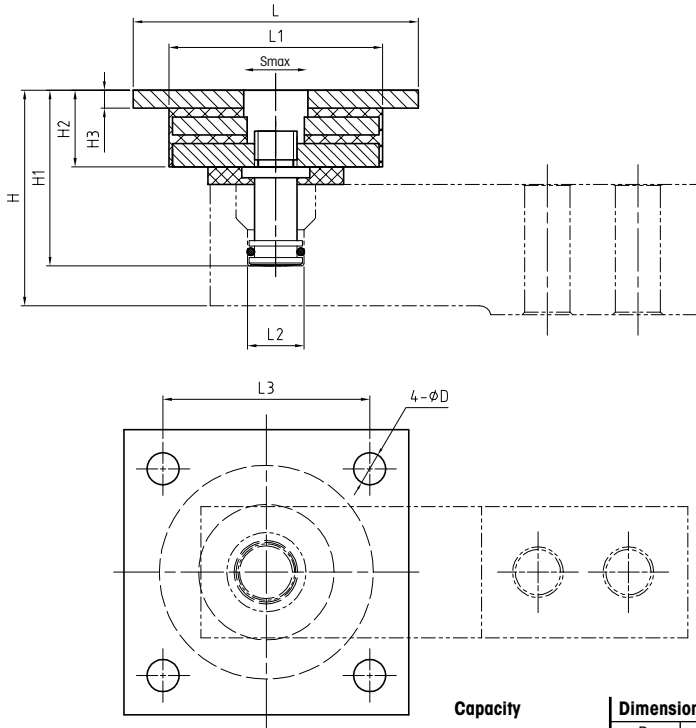

Materials: Stainless steel, NBR 70, Polyethylene foam

Capacity	Dimensions and Locations									
	D	L	L1	L2	L3	H	H1	H2	H3	Smax*
110 kg-1.1 t	ø9 [ø0.35]	ø80 [ø3.15]	ø58 [ø2.28]	ø15 [ø0.59]	58 [2.28]	56.6 [2.23]	44.1 [1.74]	21.5 [0.85]	5 [0.20]	±3 mm [±0.12]
2.2 t	ø9 [ø0.35]	ø80 [ø3.15]	ø58 [ø2.28]	ø15 [ø0.59]	58 [2.28]	60.5 [2.38]	49.3 [1.94]	21.5 [0.85]	5 [0.20]	±3 mm [±0.12]
4.4 t	ø11 [ø0.43]	ø100 [ø3.94]	ø72 [ø2.83]	ø21.5 [ø0.85]	76 [2.99]	75.6 [2.98]	64.4 [2.54]	30 [1.18]	10 [0.39]	±3 mm [±0.12]

* Max lateral displacement

0745A Base Plate Kit BPK mm [inch]

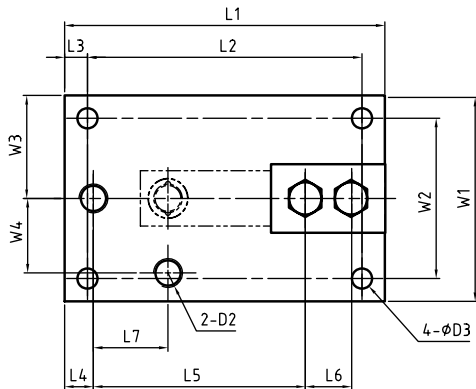

Materials: Stainless steel or painted steel

Capacity	Dimensions and Locations										
	L1	L2	L3	L4	L5	L6	L7	W1	W2	W3	W4
110 kg-1.1 t	177.8 [7]	152.4 [6]	12.7 [0.5]	16.0 [0.63]	117.6 [4.63]	25.4 [1]	41.4 [1.63]	114.3 [4.5]	88.9 [3.5]	57.2 [2.25]	41.4 [1.63]
2.2 t	177.8 [7]	152.4 [6]	12.7 [0.5]	16.0 [0.63]	117.6 [4.63]	25.4 [1]	41.4 [1.63]	114.3 [4.5]	88.9 [3.5]	57.2 [2.25]	41.4 [1.63]
4.4 t	235.0 [9.25]	184.2 [7.25]	25.4 [1]	22.4 [0.88]	149.4 [5.88]	38.1 [1.5]	54.1 [2.13]	152.4 [6]	101.6 [4]	76.2 [3]	54.1 [2.13]

Capacity	Dimensions and Locations									
	H1	H2	H3	H4	D1	D2	D3	MA cs ¹	MA ss ²	
110 kg-1.1 t	70.2 [2.76]	62.0 [2.44]	19.1 [0.75]	12.7 [0.5]	M12	M16	11.2 [0.44]	136 Nm [100 lb-ft]	100 Nm [75 lb-ft]	
2.2 t	76.5 [3.01]	68.4 [2.96]	19.1 [0.75]	12.7 [0.5]	M12	M16	11.2 [0.44]	136 Nm [100 lb-ft]	100 Nm [75 lb-ft]	
4.4 t	99.6 [3.92]	87.4 [3.44]	25.4 [1]	19.1 [0.75]	M18	M18	17.5 [0.69]	340 Nm [250 lb-ft]	270 Nm [200 lb-ft]	

1) Torque carbon steel version

2) Torque stainless steel version

0745A Load Cell Order Information

Description	Item No.
Load cell, model no. 0745A, 110kg/250lb 2.2m (7.5ft) cable	72233956
Load cell, model no. 0745A, 110kg/250lb 4.5m (15ft) cable	72233957
Load cell, model no. 0745A, 110kg/250lb 9.1m (30ft) cable	72233958
Load cell, model no. 0745A, 110kg/250lb 2.2m (7.5ft) FEP cable	72233959
Load cell, model no. 0745A, 110kg/250lb 4.5m (15ft) FEP cable	72233960
Load cell, model no. 0745A, 220kg/500lb 2.2m (7.5ft) cable	64052903
Load cell, model no. 0745A, 220kg/500lb 4.5m (15ft) cable	64052904
Load cell, model no. 0745A, 220kg/500lb 9.1m (30ft) cable	64052905
Load cell, model no. 0745A, 220kg/500lb 2.2m (7.5ft) FEP cable	64052906
Load cell, model no. 0745A, 220kg/500lb 4.5m (15ft) FEP cable	64052907
Load cell, model no. 0745A, 550kg/1,250lb 2.2m (7.5ft) cable	64052908
Load cell, model no. 0745A, 550kg/1,250lb 4.5m (15ft) cable	64052909
Load cell, model no. 0745A, 550kg/1,250lb 9.1m (30ft) cable	64052910
Load cell, model no. 0745A, 550kg/1,250lb 18.2m (60ft) cable	64052911
Load cell, model no. 0745A, 550kg/1,250lb 2.2m (7.5ft) FEP cable	64052912
Load cell, model no. 0745A, 550kg/1,250lb 4.5m (15ft) FEP cable	64052913
Load cell, model no. 0745A, 550kg/1,250lb 9.1m (30ft) FEP cable	64052914
Load cell, model no. 0745A, 1100kg/2,500lb 2.2m (7.5ft) cable	64052915
Load cell, model no. 0745A, 1100kg/2,500lb 4.5m (15ft) cable	64052916
Load cell, model no. 0745A, 1100kg/2,500lb 9.1m (30ft) cable	64052917
Load cell, model no. 0745A, 1100kg/2,500lb 18.2m (60ft) cable	64052918
Load cell, model no. 0745A, 1100kg/2,500lb 2.2m (7.5ft) FEP cable	64052919
Load cell, model no. 0745A, 1100kg/2,500lb 4.5m (15ft) FEP cable	64052920
Load cell, model no. 0745A, 1100kg/2,500lb 9.1m (30ft) FEP cable	64052921
Load cell, model no. 0745A, 2200kg/5,000lb 2.2m (7.5ft) cable	64052922
Load cell, model no. 0745A, 2200kg/5,000lb 4.5m (15ft) cable	64052924
Load cell, model no. 0745A, 2200kg/5,000lb 9.1m (30ft) cable	64052925
Load cell, model no. 0745A, 2200kg/5,000lb 18.2m (60ft) cable	64052926
Load cell, model no. 0745A, 2200kg/5,000lb 2.2m (7.5ft) FEP cable	64052927
Load cell, model no. 0745A, 2200kg/5,000lb 4.5m (15ft) FEP cable	64052928
Load cell, model no. 0745A, 2200kg/5,000lb 9.1m (30ft) FEP cable	64052929
Load cell, model no. 0745A, 4400kg/10,000lb 4.5m (15ft) cable	64052930
Load cell, model no. 0745A, 4400kg/10,000lb 9.1m (30ft) cable	64052931
Load cell, model no. 0745A, 4400kg/10,000lb 18.2m (60ft) cable	64052932
Load cell, model no. 0745A, 4400kg/10,000lb 4.5m (15ft) FEP cable	64052933
Load cell, model no. 0745A, 4400kg/10,000lb 9.1m (30ft) FEP cable	64052934
BASE PLATE KIT BPK Carbon Steel 0745 110 kg -1.1 t	72208664
BASE PLATE KIT BPK Carbon Steel 0745 2.2 t	72209167
BASE PLATE KIT BPK Carbon Steel 0745 4.4 t	72208665
BASE PLATE KIT BPK Stainless Steel 0745 110 kg -1.1 t	72208666
BASE PLATE KIT BPK Stainless Steel 0745 2.2 t	72209168
BASE PLATE KIT BPK Stainless Steel 0745 4.4 t	72208667
EXPANSION KIT EK Stainless Steel 0745 110 kg -2.2 t	72208662
EXPANSION KIT EK Stainless Steel 0745 4.4 t	72208663
EXPANSION+VIBR KIT EVK Stainless Steel 0745 110 kg -2.2 t	72208670
EXPANSION+VIBR KIT EVK Stainless Steel 0745 4.4 t	72208671
FOOT KIT FTK Stainless Steel 0745 110 kg -2.2 t	72208674
FOOT KIT FTK Stainless Steel 0745 4.4 t	72208675

Bolded entries are stocked

0745A Load Cell Cable Colours

Colour	Function
Green	+ Excitation
Black	- Excitation
White	+ Signal
Red	- Signal
Yellow	Shield

METTLER TOLEDO Service

Our extensive service network is among the best in the world and ensures maximum availability and service life of your product.



Quality certificate ISO 9001
Environment certificate ISO 14001

Subject to technical changes.
© 09/2012 Mettler-Toledo AG
Printed in Switzerland MTSI 44099791
MarCom Industrial



Weighing Electronics

METTLER TOLEDO offers a complete family of electronics from simple weighing to application solutions for filling, stock control, batching, formulation, counting, checkweighing.

www.mt.com

Visit for more information